

jeas_0719_7837_5_1.pdf

by

FILE	JEAS_0719_7837_5_1.PDF (611.76K)	WORD COUNT	5512
TIME SUBMITTED	07-JAN-2020 05:46PM (UTC+0700)	CHARACTER COUNT	26276
SUBMISSION ID	1239746018		



TRANSIENT STABILITY IMPROVEMENT BASED ON MOMENT INERTIA INDEX USING EXTREME LEARNING MACHINE

Indar Chaerah Gunadin¹, Zaenab Muslimin¹ and Agus Siswanto²

¹Department of Electrical Engineering, Hasanuddin University, Indonesia

²Department of Electrical Engineering, Universitas Tujuh Belas Agustus, Cirebon, Indonesia

E-Mail: indar@eng.unhas.ac.id

ABSTRACT

Power system stability have emerged and become problematic issue in recent years, transient stability still remains a basic and important consideration in power system operation, security and maintenance. Transient stability assessment become topic of the problems that continue to attract the attention of researchers in the world. These early stability problems, often a result of insufficient synchronizing torque, were the first emergence of transient stability. Moment inertia and Critical Clearing Time (CCT) are key parameter for Transient Stability Improvement. In this paper will proposed a new technique for improvement CCT value using inertia moment index of all generator. By rescheduling the generation based on the value of the inertia moment, the critical clearing time (CCT) of the system will be increased. After the CCT value is obtained based on moment inertia index, then the value of CCT is learned by Extreme Learning Machine. In this paper, WSCC 9 bus system will be a test case. The simulation result show that, rescheduling active power based on moment inertia index can improve CCT and the Extreme Learning Machine can be a robust method to obtain a CCT with minimum error.

Keywords: transient stability, critical clearing time, moment inertia, extreme learning machine.

1. INTRODUCTION

Currently, the power system is experiencing very rapid development, resulting in the emergence of power system stability problems. The rapid growth of the load causes the power system to operate in a heavily stressed condition. These conditions lead to the transient stability problem in the system. The problem in transient stability has been the major cause for blackout cases all over the world recently [1]. Major disruptions to the electrical system provide problems at the rotor angle or transient stability.

The need of power has been changing in every single day since the peak load occurs in early evening. The balance between power demand on power and power on generator must be carefully maintained [2-3]. There are many of incidents in power system diagnosed as transient stability problems caused by the increased loading and decreased stability margin. The stability margin may be defined as the distance between the loading of the system and the maximum loading limit of the system [1-3].

There are several causes of transient stability in the power system. Including: the occurrence of short circuit, lightning strikes, the release of large plants and the breakdown of power system transmission. The interference will cause the oscillation of the rotor angle at the generator, which can then cause the generator to be out of synchronous.

Voltage stability has been the trigger for cases of total outages in the electric power system. The power that can be transferred from a bus to another bus in the power system has limits. These limits are influenced by the value of transmission impedance and voltage magnitude. When the maximum power transfer level is exceeded, the stability phenomenon will occur.

Continuous distribution of electrical power must be maintained with voltage levels and frequencies within

the allowable limits. In the operation of electric power, it is strongly prevented by a power outage in a large area due to interferences [4]. Power outages on a large scale will cause large losses on the consumer side as well as on electricity companies. Large-scale electricity blackouts will result in large losses, both material and immaterial [5]. To produce continuous and good quality electrical power, very good power system control and stability are needed.

In a large-scale electric power system consisting of several plants and loads that are interconnected in an interconnection system, improving system stability becomes an important and complex problem. In order to keep the electrical system in continuous and stable operation, good regulation and stability improvements are needed. One parameter of power system stability is transient stability. Transient stability is the ability of an electric power system to achieve a stable condition from the condition of a new operating point that can be received at the time after a major disturbance occurs [4-7].

There are several conventional computational methods commonly used to interpret the conditions of transient stability in an electrical power system including using the time domain simulation (TDS) method, transient energy functions, the same criteria method, and several other methods. The method generally does not include the effect of the generator output power values on the interpretation of transient stability results [8-9].

There are several methods that can be used to improve the transient stability of the electric power system, including: installing VAR support equipment, installing FACTS yard equipment, installing new transmission lines and others. In this study we will offer a method for increasing transient stability by doing generation rescheduling using the H index method. This study aims to examine the relationship between active



power plants to improve system stability by looking at the Critical Clearing Time (CCT) value of the system. As a test case, the WSCC 9 bus system was used. Increasing critical clearing time can be done by scheduling a generator based on the moment of inertia value which then uses an extreme learning machine the relationship between CCT and generating power can be determined.

2. POWER SYSTEM STABILITY

A. Stability in Power System

The ability of an electric power system to return a power equal to or greater than the strength of a disturbance to maintain a balanced state is called stability. If in the event of a disturbance, which makes all the variables in the system still within the permitted limits and still makes the working generator still in synchronous conditions with the others, then the system is said to be stable (synchronous) [10-13].

When the power system operates in a stable condition, a power balance occurs between the mechanical input power produced by the generator from the generator and the electrical output power (electrical load) on the system. Under these conditions all generators in the system operate at synchronous speeds. When there is a small or large disturbance in the power system, it will have an impact on the synchronous operation of all the plants in the system. In the event of a sudden increase or decrease in load, the consequence will be the loss of generation at one or more plants. Another form of interference that can occur in the system is the transmission of the network, overload, or short circuit due to lightning strikes on the transmission network. By providing improvements to the system and improving existing controls, it is expected that the system's transient stability will increase so that the system can return to being stable in a short period of time [14].

In electric power systems, this type of disturbance can be categorized into 2 categories, namely large disturbances and small disturbances. [1-2]. In the study of small disturbances, dynamic system elements are modelled in the form of linear equations. Minor disturbances can be caused by changes in load or changes in the generator randomly and slowly. Disturbance that result in sudden changes to all system variables are the main types of disturbance that must be immediately removed from the system. If the disturbance is not immediately removed, then the disturbance will affect system stability. Large-scale disturbance will have a significant effect on the flow of power on the system, an event that allows blackouts conditions.

Stability studies can be classified into 3 forms, namely steady state stability, dynamic stability, and temporary stability [16]. Stable state stability is the ability of the electric power system to achieve stable conditions under new operating conditions that are identical or identical to the conditions before the disturbance occurs after the system has experienced a small disturbance. Conceptually, dynamic stability is the same as steady state stability [5]. Figure-1 shows the classification of power

system stability. The difference lies in modelling, that is, in dynamic stability, excitation systems, turbines, and generators modelled by providing flux variations in engine water, while the stability of steady state generators is presented as a constant voltage source [1-2]. While transient stability is the ability of the power system to achieve stable conditions under acceptable new operating conditions after the system experiences a large scale disruption in the period during the first swing assuming the AVR and the governor have not functioned [13].

Transient stability studies are needed to ensure that electric power systems are able to withstand transient conditions after a major disturbance occurs. This can be seen from the value of the critical termination time in the event of a disturbance.

Transient stability is carried out when there are transmission facilities and new plants that will be installed in the power system and are very helpful in determining the relay system needed the breaker breakdown time, voltage level, and inter-system transfer capability of system [11-16].

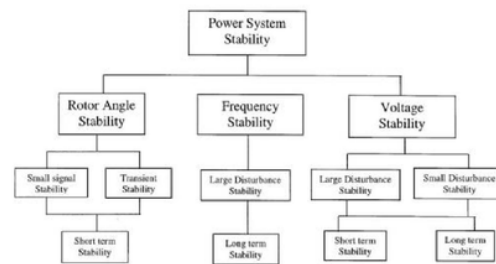

Figure-1. Classification of Power System Stability.

2.1 Swing Equation

The swing equation is used to express the rotor movement on a machine simultaneously, and is the basic principle that states that the acceleration of acceleration is the product of the moment of rotor inertia with its angular acceleration. The equation can be written as follows:

$$J \cdot \frac{d^2\theta}{dt^2} = T_a = T_m - T_e \quad (1)$$

The symbols above have the meaning as follows:
With dot notation writable

$$\ddot{\delta} = \frac{d^2\delta}{dt^2}$$

So that,

$$J\ddot{\delta} = T_m - T_e \quad (2)$$

Several ways are used from the development of equations:

$$J\ddot{\delta} = T_m - T_e$$



by multiplying both sides with ω then;

$$J\omega\ddot{\delta} = P_m - P_e \tag{3}$$

with J is the constant of inertia and angular momentum is M , then M can be expressed by:

$$M = J\omega$$

The power equation is:

$$M\ddot{\delta} = P_m - P_e \tag{4}$$

the second way derived from kinetic energy is:

$$W_k = \left(\frac{1}{2}\right)J\omega_R^2 \tag{5}$$

constants H

$$H = \frac{W_k}{P_R}$$

then the equation per unit or swing equation is:

$$\left(\frac{2H}{\omega_R}\right)\ddot{\delta} = T_{mpu} - T_{epu} \tag{6}$$

3. EXTREME LEARNING MACHINE

Conventional methods such as back-propagation (BP) and the method of Levenberg-Marquardt (LM) have been used extensively in training neural networks although this algorithm is relatively slow in learning. A new learning method for single-hidden-layer feed forward neural-networks (SLFNs) is the so-called extreme learning machine (ELM). In ELM, the input weights and hidden biases are randomly chosen. The output weights obtained using the Moore-Penrose (MP) generalize inverse. ELM has the capability in terms of speed and it is easier than traditional methods of gradient-based learning algorithms [17-19].

In ELM, the input weights and hidden biases are generated randomly. Furthermore, the nonlinear system has been transformed into a linear system:

$$H\beta = T$$

Whereas named in Huang et al. [17-18], $H = \{h_{ij}\}$ ($i=1, \dots, N$, $j=1, \dots, K$) is hidden-layer output matrix, $\beta = [\beta_1, \beta_2, \dots, \beta_K]^T$ is matrix of output weights and $T = [t_1, t_2, \dots, t_N]^T$ is matrix of targets.

In this paper, ELM is utilized to map the highly non-linear relationship between network voltage profile, power generation of power system and the corresponding bus participation factor of power system. First, the simulation starts with running the power flow program for WSCC 9 bus system. Then, by using transient stability based on moment inertia index, the Critical Clearing Time (CCT) will be obtained. The data from transient stability analysis will be training in ELM.

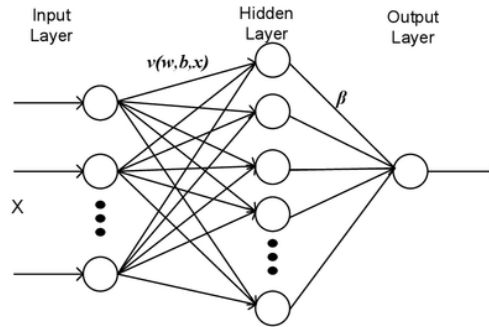

Figure-2. Structure of an SLF-NN.

4. PROPOSED METHOD

This research proposes a method to improve the stability of transient system by performing rescheduling of active power generation based on proportional moment inertia constant (H) value of each generator. WSCC 9 bus system is the test case of simulation, shown on Figure-2.

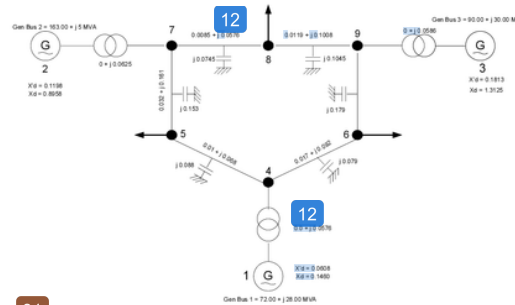

Figure-3. Single line diagram of WSCC 9 bus system.

The steps undertaken in this study are:

- Generator data collection, transmission and load of system
- Running transient stability analysis
- Looking at the critical clearing time (CCT)
- Change the active power generation
- Conducting rescheduling with the value of index H
- Compare the CCT value for each method of generating scheduling
- Conduct training and testing data on Extreme Learning Machine

The procedure of this research in complete can be seen on the Figure-3.

Table-1. Moment Inertia Of Generator.

No.	Generator	X_d'	H (Moment Inertia)
1	Generator 1	0.0608	23.64
2	Generator 2	0.1198	6.40
3	Generator 3	0.1813	3.01



Table-2. Load Flow Data.

Bus to	Bus	R (p.u)	X(p.u)	1/2B (p.u)
1	4	0.00000	0.05917	0.0000
2	7	0.00000	0.06250	0.0000
3	9	0.00000	0.05860	0.0000
4	5	0.01000	0.06800	0.0880
4	6	0.01700	0.09200	0.0790
5	7	0.03200	0.16100	0.1530
6	9	0.03900	0.17380	0.1790
7	8	0.00850	0.05760	0.0745
8	9	0.01190	0.10080	0.1045

The method offered to improve the stability of the system in this paper is rescheduling of the plant based on the value of the generator inertia moment. Each power generator will generate power according to the value of its inertial moment. The great equation for explaining the power value of each generator can be seen in equation (7).

$$P_{Generation} = \frac{H_{Generator}}{Total H_{Generator}} \times P_{Total} \quad (7)$$

Using equation (7), we obtain the power of each generator based on the moment inertia value. At the time of total power at 315 MW load using equation (7), the power of generator 1 (G1) is 225 MW, 61 MW and 29 MW, respectively for G2 and G3. For more details can be seen in Table-3

Table-3. Result Of Power Rescheduling Based On Inertia Value.

Proportional Power Generation Based On Moment Inertia				
No.	G1 (MW)	G2 (MW)	G3 (MW)	Load Demand
1	225.3132	60.9985	28.6884	315
2	232.466	62.9349	29.5991	325
3	239.6188	64.8714	30.5098	335
4	246.7716	66.8079	31.4206	345
5	253.9244	68.7443	32.3313	355
6	261.0772	70.6808	33.2421	365
7	268.23	72.6172	34.1528	375
8	275.3828	74.5537	35.0635	385
9	282.5356	76.4902	35.9743	395

In this paper, we show the relation between the changes of load on the other bus to the value of CCT on the bus that has interference. Suppose that on bus 9 fault occurs, it is simulated when load on bus 5, bus 6 and bus 8 are changed for fixed slack bus. The purpose of the simulation is to see the effect when a generator becomes slack bus with the moment value to the existing CCT value. Is there any connection between slack bus selections to CCT value is the purpose of this simulation.

We also examined the relationship between the values of CCT to economical scheduling by using

lagrange method. Then it will be seen large operating costs for each operation pattern. There are 3 operating conditions that will be compared that is base case, economic dispatch using lagrange method and proposed method.

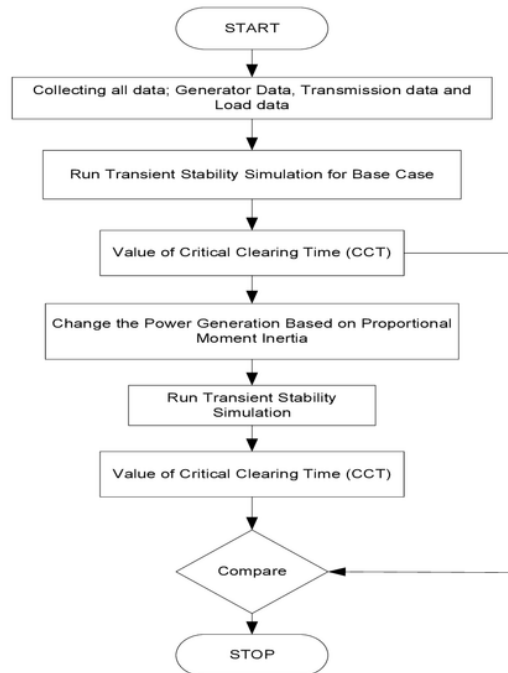

Figure-4. Research Procedure.

5. SIMULATION RESULT

The first step in this research is to study load flow for WSCC 9 bus system. The value can be seen in Table-4.

Table-4. Load Flow Result For Base Case.

Bus No.	Gen MW	Gen MVar	Load MW	Load Mvar	V (p.u)	Angle (degree)
1	72	28			1.04	
2	163	5			1.025	9.351
3	85	-11			1.025	5.142
4					1.025	-2.217
5			125	50	0.9997	-3.680
6			90	30	1.012	-3.567
7					1.027	3.796
8			100	35	1.017	1.337
9					1.033	2.445

After the load flow simulation then the next step is to do some scenarios for transient stability simulation. The scenarios are as follows:

- Base Case Scenario: Power allocation is appropriate to the initial conditions
- Proposed Method Scenario: The allocation of power generation is determined by the value of the inertia



moment of the plant CCT Relationship to Load Demand Changes

- Conduct training on CCT data in Extreme Learning Machine.

5.1 CCT Relationship to Load Demand Changes

The simulation shows the relationship between load changes on bus 5, bus 6 and bus 8, in the event of interference at bus 9. The simulation result shows an increase of CCT value when the load on the bus is increased. To see it can be seen in Tables (5-7).

Table-5. Fault On Bus 9 With Load Change On Bus 5.

Fault	Load bus 5 (MW)	CCT (second)
9	125 MW	0.219
9	135 MW	0.224
9	145 MW	0.228
9	175 MW	242

Table-6. Fault On Bus 9 With Load Change On Bus 6.

Fault	Load bus 6	CCT
9	100 MW	0.17
9	110 MW	0.18
9	120 MW	0.18
9	130 MW	0.19
9	140 MW	0.19

Table-7. Fault On Bus 9 With Load Change On Bus 8.

Fault	Load bus 8	CCT
9	110 MW	0.173
9	120 MW	0.184
9	130 MW	0.195
9	140 MW	0.21
9	150 MW	0.214
9	175 MW	0.226
9	200 MW	0.243

The rotor angle respon of each generator can be seen on Figure-4. Fault on bus 9 with total load demand is 145 MW.

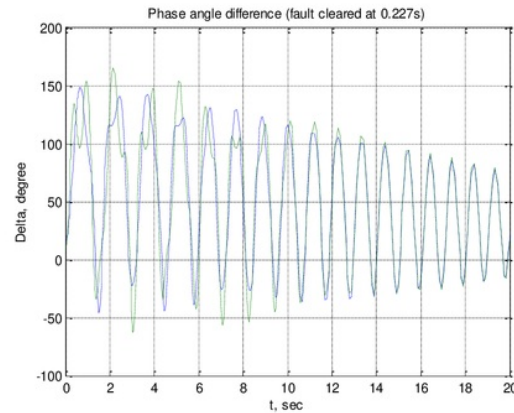

Figure-5. Rotor Angle Respon when Fault on bus 9 with total load demand on bus 5 is 145 MW.

In this research, some simulation scenarios are done:

- There is a short circuit on bus 7 by removing line 5-7
- There is a short circuit on bus 8 by removing line 7-8
- There is a short circuit on bus 5 by removing line 4-5
- There is a short circuit on bus 6 by removing line 4-6
- There is a short circuit on bus 9 by removing line 6-9

The rotor angle response for base case condition at fault on bus 7 for interruption time for 0.16237 seconds. As shown in Figure-6.

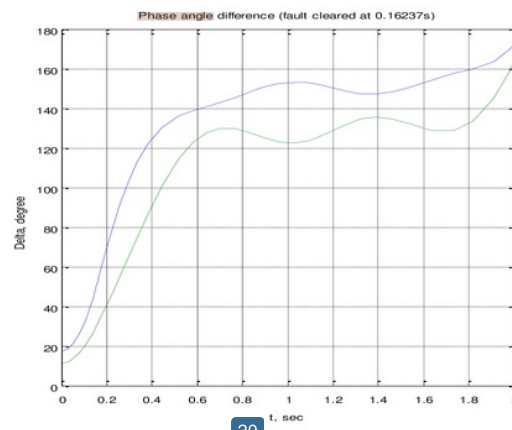

Figure-6. The rotor angle response for base case condition at fault on bus 7 for interruption time for 0.16237 seconds.

For generating conditions obtained using lagrange method obtained power sharing for each plant as follows:

Active Power Generation G1 (P1) = 90.3845 MW
 Active Power Generation G2 (P2) = 134.2522 MW
 Active Power Generation G3 (P3) = 94.1720 MW



Operation Cost = 5309,2 \$/h

Rotor angle response for discharging economic dispatch result condition at fault on bus 7 for critical clearing time is 0.2285 sec. As shown in Figure-7.

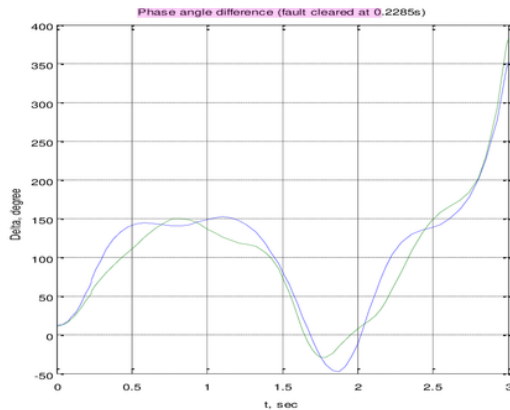

Figure-7. The rotor angle response for economic dispatch method, when fault on bus 7 for interruption time for 0.2285 seconds.

For generating conditions obtained using Lagrange method obtained power sharing for each plant as follows:

Active Power Generation G1 (P1) = 90.3845 MW
 Active Power Generation G2 (P2) = 134.2522 MW
 Active Power Generation G3 (P3) = 94.1720 MW
 Operation Cost = 5309,2 \$/h

Rotor angle response for discharging economic dispatch result condition at fault on bus 7 for critical clearing time is 0.2285 sec. As shown in Figure-7.

Furthermore, by rescheduling the generator based on the value of index H obtained the value of each generator as follows:

Active Power Generation G1 (P1) = 229.169 MW
 Active Power Generation G2 (P2) = 60.999 MW
 Active Power Generation G3 (P3) = 28.688 MW
 Operation Cost = 8526,9 \$/h

After generating values are obtained, proceed with determining the critical clearing time value by looking at the rotor angle response of each generator.

From the simulation shows that in the event of fault on bus 7, then the critical clearing time obtained for 0.7 seconds. As shown in the Figure-8.

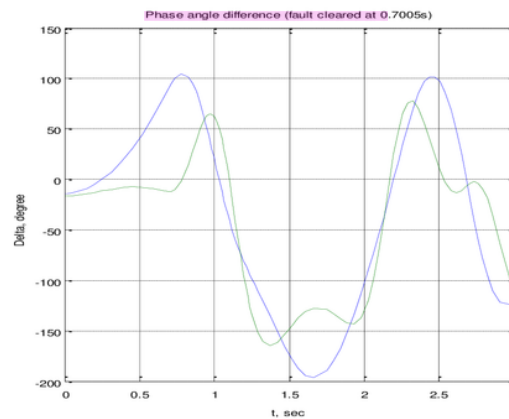

Figure-8. The rotor angle response for proposed method, when fault on bus 7 for interruption time for 0.700 seconds.

Table-8. Sample of Data Input For Extreme Learning Machine for Wsc 9 Bus System.

23	Bus Voltage	Bus Voltage	Bus Voltage	Bus Voltage	Bus Voltage	Bus Voltage	Bus Voltage	Bus Voltage	Bus Voltage	Real Power (G1)	Real Power (G2)	Real Power (G3)	18	Load (MW)	Load (MW)	Load (MW)	Load (MW)	Load (MW)	Load (MW)	CCT
1.04	1.025	1.025	1.025	0.999	1.012	1.027	1.017	1.033	71.628	163	85	0	125	90	0	100	0	0	0.301	
1.04	1.025	1.025	1.025	0.999	1.012	1.027	1.017	1.033	73.646	163	85	0	127	90	0	100	0	0	0.303	
1.04	1.025	1.025	1.025	0.999	1.012	1.027	1.017	1.033	75.664	163	85	0	129	90	0	100	0	0	0.305	
1.04	1.025	1.025	1.025	0.999	1.012	1.027	1.017	1.033	77.683	163	85	0	131	90	0	100	0	0	0.308	
1.04	1.025	1.025	1.025	0.998	1.012	1.027	1.017	1.033	79.703	163	85	0	133	90	0	100	0	0	0.311	
1.04	1.025	1.025	1.025	0.998	1.012	1.026	1.017	1.033	81.724	163	85	0	135	90	0	100	0	0	0.312	
1.04	1.025	1.025	1.025	0.998	1.012	1.026	1.017	1.033	83.746	163	85	0	137	90	0	100	0	0	0.315	
1.04	1.025	1.025	1.025	0.998	1.012	1.026	1.017	1.032	85.768	163	85	0	139	90	0	100	0	0	0.317	
1.04	1.025	1.025	1.024	0.997	1.012	1.026	1.017	1.032	87.791	163	85	0	141	90	0	100	0	0	0.319	
1.04	1.025	1.025	1.024	0.997	1.012	1.026	1.017	1.032	89.815	163	85	0	143	90	0	100	0	0	0.322	

From the simulation it can be seen that by applying the proposed method, there is an increase of CCT value. This means that the proposed method can improve

the transient stability of the system. Comparison of CCT values for the three scenarios can be seen in the Table-9.

**Table-9.** Comparison Of Cct For All Scenario.

No	Fault	Line Open	CCT (second) Base Case	CCT (second) ED	CCT (Second) Proposed Method
1.	Bus 7	line 5-7 open	0.16237	0.2286	0.7100
2.	Bus 8	line 7-8 open	0.2700	0.3455	stable
3.	Bus 5	line 4-5 open	0.3820	0.4710	stable
4.	Bus 6	line 4-6 open	0.4583	0.5835	stable
5.	Bus 9	line 6-9 open	0.2185	0.2250	0.7500

Table-10. Comparison Between Cct Of Proposed Method Versus Actual Cct.

No.	Total Load (MW)	CCT of Proposed Method (s)	Actual CCT (s)
1	315	Stabil	0.301
2	325	Stabil	0.312
3	335	Stabil	0.324
4	345	Stabil	0.337
5	355	Stabil	0.351
6	365	Stabil	0.362
7	375	Stabil	0.374
8	385	Stabil	0.381
9	395	Stabil	0.393

Table-10 shows that by applying the proposed method the tendering system is more stable to the fault. For a total load of 315 MW, at the time of interference occurs in bus 5, for the base system obtained CCT value of 3.01 seconds for the system with the proposed method is stable condition.

5.2 Application Extreme Learning

After performing the load flow study, the next step is to study transient stability. By making changes to the generation by applying the moment inertia index method, a better CCT system is obtained. The value of CCT obtained later in learning on the method of Extreme Learning Machine (ELM). The active and reactive power of the load, the reactive active power of the generator, the voltage at the load bus and the generator, becomes the input on the ELM while the CCT value data becomes output on the ELM. In Figure-9 shown the input and output data on ELM.

Table-8 shows the sample data input for ELM. The data is a simulation data for the location of three phase fault on bus 5 with a tripped line is the line connecting between bus 5 and bus 7. Simulation is done by continuing to increase the load on bus 5 with an increase of 2 MW each step simulation. Then the study transient stability to determine the value of CCT if the fault occurs in bus 5.

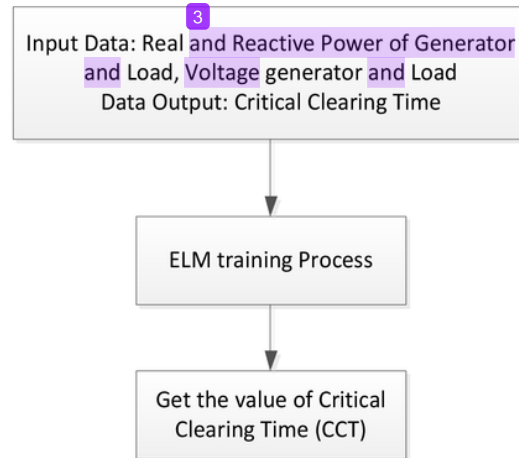
**Figure-9.** Simulation process of ELM Method.

Activation function in this simulation was the sigmoid method. After the simulation, the results obtained were:

Average Training Accuracy = 1.9332e-28
 Average Testing Accuracy = 1.0303e-04
 Average Training Time = 0.0657
 Average Testing Time = 0.0143

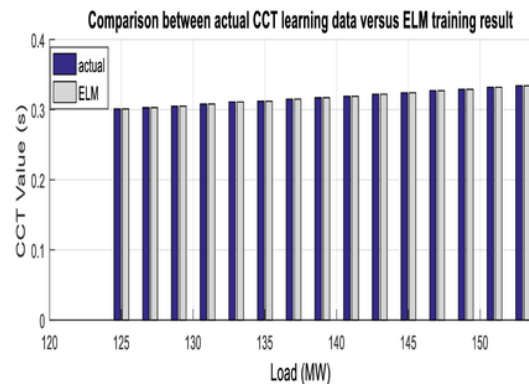
**Figure-10.** Result of ELM Training for WSCC 9 Bus System.

The proposed ELM architecture can have 18 input nodes and 1 output nodes and only one hidden layer is used. Sigmoid types of additive hidden nodes are used in this ELM.

In this paper, the performance of ELM is compared with actual CCT result. Figure-10 and Figure-11 show the result of ELM training and the ELM prediction.

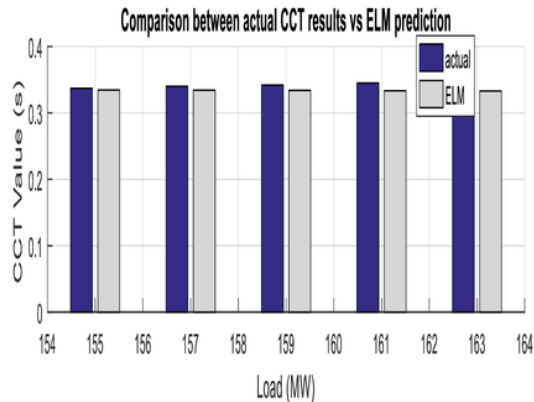

Figure-11. Result of ELM Testing for WSCC 9 Bus System.

Actual data values and learning PF data were obtained from the ELM comparison and the error value was obtained as shown in Table-11. From the error results, it could be seen that the ELM was very accurate and **f₁** in determining transient stability assessment. From the overall error in the output values for the given example is less than 0.0436% which will be acceptable and the method has strong potential for transient stability assessment.

Table-11. The Comparison of Data Testing and Elm Results for Wsc 9 Bus System.

Testing Data CCT	Learning CCT (ELM)	Errors
0.337	0.3345	0.0073
0.34	0.3343	0.0165
0.342	0.3339	0.0232
0.345	0.3334	0.0333
0.348	0.3328	0.0436

6. CONCLUSIONS

From the simulation results, it can be seen that by using scheduling method based on H index value, it is found that *critical clearing time* (CCT) value becomes more stable, so the system is more robust **4** disturbance. The value of the H index can be a solution to improve the stability of the power system.

In this paper, the estimated result obtained from ELM method showed that this approach was able to predict the Critical Clearing Time (CCT) in power system. The result showed that ELM had overall error in output values was less 0.043 which would be acceptable and it meant that the ELM method had strong potential to be a useful tool for a transient stability assessment.

REFERENCES

- [1] Hadi S. 1999. Power System Analysis, McGraw-Hill Book Co., Singapore.
- [2] Allen J.W., dan Bruce F.W. 1996. Power Generation, Operation, and Control. John Wiley & Sons Inc., Canada.
- [3] Anderson P. M. and Fouad A. A. 1990. Power System Control and Stability, Iowa University Press, Ames, Iowa.
- [4] Zhenyu Huang, Lixin Bao, and Wilsun Xu. 2006. A Method to measure QV curves and it's Application in Power System, Electrical Power and Energy Systems. pp. 147-154.
- [5] Campeanu H. S., L'Helguen E., Assef Y., Vidal N. and Savulescu S. C. 2006. Real-Time Stability Monitoring at Transelectrica., IEEE PSCE 2006 Atlanta, GA, October 29-November 2.
- [6] Gunadin I.C., Abdillah M., Soeprijanto A., Penangsang. 2012. Determination of steady state stability margin using extreme learning machine. WSEAS Transactions on Power Systems.
- [7] Gunadin I.C., Soeprijanto A., Penangsang O. 2012. Steady state stability assessment using extreme learning machine based on modal analysis. International Review of Electrical Engineering.
- [8] Pitono J., Soeprijanto A., Purnomo M.H., Gunadin I.C. 2013. Power generation optimization based on steady state stability limit using particle swarm optimization (PSO). International Review on Modelling and Simulations.
- [9] Gunadin, I.C., Soeprijanto, A., Penangsang O. 2010. Real power generation scheduling to improve steady state stability limit in the Java-Bali 500 kV interconnection power system. World Academy of Science, Engineering and Technology.
- [10] Indar Chaerah Gunadin, Adi Suprijanto, Ontoseno Penangsang. 2009. Study on Effect of STATCOM Installation to Improved Voltage Stability in East Indonesia System. Proceeding of National Seminar on Applied Technology, Science, and Art (APTECS), Surabaya, December 22.
- [11] Indar Chaerah Gunadin, Adi Suprijanto, Ontoseno Penangsang. 2010. Effect of VAR Suppor Installation



- to Improved Voltage Stability in East Indonesia System. Proceeding of Basic Science National Seminar 7th, February 20th.
- [12] Indar Chaerah Gunadin, Nadjamuddin Harun, Adi Suprijanto. 2009. Transient Stability on East Indonesia System. Proceeding of National Seminar on Applied Technology, Science, and Art (APTECS), Surabaya, December 22th.
- [13] Indar Chaerah Gunadin, Adi Suprijanto, Ontoseno Penangsang. 2010. Effect of VAR Suppor Installation to Improved Voltage Stability in East Indonesia System. Proceeding of Basic Science National Seminar 7th, February 20th.
- [14] 2009. A Novel Method for Staedy State Stability Limit Assessment. Proceeding of The 3rd International Student Conference on Advanced Science and Technology (ICAST), Seoul, Korea.
- [15] Indar Chaerah Gunadin, Nadjamuddin Harun, Adi Suprijanto. 2009. Transient Stability on East Indonesia System. Proceeding of National Seminar on Applied Technology, Science, and Art (APTECS), Surabaya, December 22th.
- [16] Indar Chaerah Gunadin, Adi Suprijanto, Ontoseno Penangsang. 2010. Effect of VAR Suppor Installation to Improved Voltage Stability in East Indonesia System. Proceeding of Basic Science National Seminar 7th, February 20th.
- [17] Huang G.-B., Zhu Q.-Y., Siew C.-K. 2006. Extreme learning machine: theory and applications. *Neurocomputing*. 70, pp. 489-501.
- [18] Huang G.-B., Xiaojian Ding, Hongming Zhou. 2010. Optimization Method Based Extreme Learning Machine for Classification, *Neurocomputing*. 74, pp. 155-163
- [19] Qin-Yu Zhu, A.K. Qin, P.N. Suganthan. 2005. Guang-Bin Huang Evolutionary extreme learning machine, *Pattern Recognition Society*. 38, pp. 1759-1763.

ORIGINALITY REPORT

% **17**
SIMILARITY INDEX

% **11**
INTERNET SOURCES

% **11**
PUBLICATIONS

% **10**
STUDENT PAPERS

PRIMARY SOURCES

- 1** www.wseas.us Internet Source % **5**
- 2** Bayu Adriyan Ashad, Indar Chaerah Gunadin, Agus Siswanto, Yusran. "Early Warning Condition Transient Stability on South Sulawesi System using Extreme Learning Machine", 2018 2nd East Indonesia Conference on Computer and Information Technology (EIConCIT), 2018 Publication % **1**
- 3** Submitted to The University of Manchester Student Paper % **1**
- 4** Submitted to Lovely Professional University Student Paper % **1**
- 5** www.waset.org Internet Source % **1**
- 6** H.H. Goh, Q.S. Chua, I.C. Gunadin, C.W. Ling, K.C. Goh. "Validation of Steady-State Stability Evaluation Exerting with Dimo's Approximation", 4th IET Clean Energy and Technology % **1**

Conference (CEAT 2016), 2016

Publication

- | | | |
|----|---|------|
| 7 | ebitik.azerblog.com
Internet Source | % 1 |
| 8 | Boris Cintula, Zaneta Eleschova, Anton Belan, Vladimir Volcko, Michal Konicek, Matus Kovac. "Impact of fault location on transient stability of synchronous generator", Proceedings of the 2014 15th International Scientific Conference on Electric Power Engineering (EPE), 2014
Publication | <% 1 |
| 9 | Submitted to University of Strathclyde
Student Paper | <% 1 |
| 10 | eprints.utp.edu.my
Internet Source | <% 1 |
| 11 | Submitted to The Hong Kong Polytechnic University
Student Paper | <% 1 |
| 12 | Roberto D. Molina Mylius. "Appendix A: Dimo's Approach to Steady-State Stability Assessment: Methodology Overview, Numerical Example, and Algorithm Validation", Real-Time Stability Assessment in Modern Power System Control Centers, 01/29/2009
Publication | <% 1 |
| 13 | M.R Aghamohammadi, S. Hashemi, M.S. | |

Ghazizadeh. "A novel approach for improving voltage stability margin by sensitivity analysis of Neural Network", 2010 Conference Proceedings IPEC, 2010

Publication

<% 1

14

Submitted to University of Bradford

Student Paper

<% 1

15

Jeremias Leda, Ferdianto Tangdililing. "Analysis of power angle difference for defining and reducing oscillation on interconnected system: A study on 150 kV South Sulawesi grid", 2017 International Conference on High Voltage Engineering and Power Systems (ICHVEPS), 2017

Publication

<% 1

16

B Mustadir Darusman, Ansar Suyuti, Indar Chaerah Gunadin. "Small Signal Stability Analysis of Wind Turbine Penetration in Sulseirabar Interconnection System", Journal of Physics: Conference Series, 2018

Publication

<% 1

17

Submitted to University of Auckland

Student Paper

<% 1

18

nocapx2020.info

Internet Source

<% 1

19

Submitted to Institute of Graduate Studies, UiTM

Student Paper

<% 1

-
- 20 Hadi Suyono, Mahfudz Shidiq, Alfian Nur Ferdianzah, Teguh Utomo, Ismail Musirin, Lilik J. Awal. "Dynamic Stability Impact of the Hybrid Wind and Microhydro Renewable Energy Sources on the Distribution System", 2018 Electrical Power, Electronics, Communications, Controls and Informatics Seminar (EECCIS), 2018
Publication <% 1
-
- 21 Submitted to University of Leicester
Student Paper <% 1
-
- 22 www.ijert.org
Internet Source <% 1
-
- 23 gamezscreen.com
Internet Source <% 1
-
- 24 Submitted to University of Queensland
Student Paper <% 1
-
- 25 waset.org
Internet Source <% 1
-
- 26 Mohsen Rezaie Estabragh, Mohsen Mohammadian. "Active power generation pattern via considering voltage stability margin improvement", 20th Iranian Conference on Electrical Engineering (ICEE2012), 2012
Publication <% 1
-

-
- 27 Submitted to City University
Student Paper <% 1
-
- 28 dr.ntu.edu.sg
Internet Source <% 1
-
- 29 Submitted to Universiti Sains Malaysia
Student Paper <% 1
-
- 30 issuu.com
Internet Source <% 1
-
- 31 Submitted to Universiti Tenaga Nasional
Student Paper <% 1
-
- 32 pt.scribd.com
Internet Source <% 1
-
- 33 Submitted to Mississippi State University
Student Paper <% 1
-
- 34 Submitted to Malaviya National Institute of Technology
Student Paper <% 1
-
- 35 Kolluri, Sharma, Mei Li, Adrian Lazo, Peng Yu, Michael Vaiman, and Marianna Vaiman.
"Automated Critical Clearing Time calculation for analyzing faults at Entergy", 2016 IEEE/PES Transmission and Distribution Conference and Exposition (T&D), 2016.
Publication <% 1
-

36

Submitted to CSU Northridge

Student Paper

<% 1

37

Submitted to Victoria University

Student Paper

<% 1

38

Submitted to Universiti Malaysia Pahang

Student Paper

<% 1

39

"Advances in Neural Networks - ISNN 2006",
Springer Nature, 2006

Publication

<% 1

EXCLUDE QUOTES ON

EXCLUDE ON

BIBLIOGRAPHY

EXCLUDE MATCHES

< 5
WORDS